

ORIGINAL INSTRUCTIONS



**Multi-function Garden Tool  
RAC4KIT-B**

**Instruction manual**



**WARNING: Read the instruction manual thoroughly before use.**

**BUILDER SAS**  
32, rue Aristide Bergès -ZI 31270 Cugnaux –France  
Made in PRC





## 1. SAFETY WARNINGS

---

Your safety and the safety of others are very important. We have provided important safety messages in this manual and on the engine. Please read these messages carefully.

A safety message alerts you to potential hazards that could hurt you or others. Each safety message is preceded by a safety alert symbol and one of three words, DANGER, WARNING, or CAUTION.

These signal words mean:

|  |  |
|--|--|
|  <b>DANGER</b>  | You WILL be KILLED or SERIOUSLY HURT if you don't follow instructions. |
|  <b>WARNING</b> | You CAN be KILLED or SERIOUSLY HURT if you don't follow instructions.  |
|  <b>CAUTION</b> | You CAN be HURT if you don't follow instructions.                      |

Each message tells you what the hazard is, what can happen, and what you can do to avoid or reduce injury.

### SAFETY INFORMATION

#### GENERAL SAFETY INSTRUCTION

- This machine can cause serious injuries. Read the instructions carefully for the correct handling, preparations, maintenance, starting and stopping of the machine. Be familiar with all controls and the proper use of the machine.
- Keep this manual handy so that you may refer to it later whenever any questions arise. Also note, if you have any questions which cannot be answered herein, contact the dealer from whom you purchased the product.
- Never allow children or anyone unable to fully understand the directions given in the manual to use the machine.

#### PERSONAL SAFETY EQUIPMENT

- When operating this machine, make sure to wear the following safety equipment:
  - (1) Helmet
  - (2) Ear protectors
  - (3) Protection goggles or face protector
  - (4) Thick work gloves
  - (5) Non-slip-sole work boots
  - (6) protective clothes
- Do not wear loose clothing, jewelry, short trousers, sandals, or go barefoot. Do not wear anything which might be caught by a moving part of the unit. Secure hair so it is above shoulder length.

#### WORK PLACE

- Never start the engine inside a closed room or building. Exhaust gases contain dangerous carbon monoxide.
- Never use the product:
  - a. When the ground is slippery or when you can't maintain a steady posture.
  - b. At night, at times of heavy fog, or at any other times when your field of vision might be limited and it would be difficult to gain a clear view of the working area.
  - c. During rain storms, during lightning storms, at times of strong or gale-force winds, or at any other times when weather conditions might make it unsafe to use the product.
- The machine may not be used unless it is undamaged and functions properly. If the equipment or parts of it have become defective, have it repaired by a specialised technician.

- Always obey the current national and international safety, health, and working regulations.
- Do not operate the machine unless you did not find any faults on checking. If a part has become defective, make sure to replace it before you use the machine again.
- The environment must be free of easily flammable and explosive materials.
- Do not overload the machine. Use the machine only for its intended purpose.
- Always work with care, and stay alert: Do not operate the machine when you are tired, ill, or under the influence of alcohol, drugs or medication, as you will no longer be able to operate the machine safely.

### **BEFOR STARTING THE ENGINE**

- Make sure that no persons or animals are within your work area when you start working.
- Make sure there are no obstacles in your work area.
- Ensure that your machine has been fully and properly assembled.
- Check that the machine works properly and make sure, in particular, that the On/Off switch works properly. Do not operate the machine with a damaged or extensively worn cutting device.
- The machine will vibrate during operation. This may cause its screws and parts to loosen. Therefore, check all screws and parts for tightness.

### **USING THE PRODUCT**

#### **▲ WARNING**

Cut only materials recommended by the manufacturer. And use only for tasks explained in the manual.

- Keep bystanders and animals at least 15 m away from the operating point. If you are approached, immediately stop the engine.
- Grip the handles firmly with both hands using your whole hand.
- Assume a firm standing position during operation:
  - Make sure you cannot slip or fall over.
  - Do not stretch your arms too far in front of you or above your shoulder level.
- After starting the engine, check to make sure that the cutting attachment stops rotating when the throttle is full released. If it continues to rotate even after the throttle has been fully released, turn off the engine and take the unit to the dealer for repair.
- If the unit starts to shake or vibrate, turn off the engine and check the whole unit. Do not use it until the trouble has been properly corrected.
- Keep all parts of your body away from rotating cutting attachment and hot surfaces.
- Never touch the muffler, spark plug, or other metallic parts of the engine while the engine is in operation or immediately after shutting down the engine. Doing so could result in serious burns or electrical shock.
- While the motor is still hot, keep the machine away from anything flammable, such as dry grass, debris, leaves or excessive lubricant.
- Before laying down the machine, make sure the engine is turned off and the cutting attachment is completely stopped !
- Never work alone!
  - Make sure you are within shouting distance or have visual or other kind of contact with another person who will be able to provide first aid in an emergency situation.
- Always be aware of your surroundings and stay alert for possible hazards that you may not hear due to the noise of the machine
- Never operate the pruner or hedge trimmer at an angle greater than 60° in order to reduce the risk of being struck by falling objects during operation.
- Avoid operating while people, especially children are nearby.
- Always beware of the danger from overhead electric-power line, keep a safe distance at least 10m from the power line

## **MAINTENANCE**

- In order to maintain your product in proper working order, perform the maintenance and checking operations described in the manual at regular intervals.
- Always be sure to turn off the engine before performing any maintenance or checking procedures.
- Proceed to maintenance and checking before storage of the full tool.

## **WARNING!**

### **The metallic parts reach high temperatures immediately after stopping the engine**

- Use only original replacement parts. Only these spare parts are guaranteed to be designed and suitable for use with this machine. Using other spare parts will void your warranty and may cause danger to yourself and your surroundings.
- In the event that any part must be replaced or any maintenance or repair work not described in this manual must be performed, please contact our servicing dealer for assistance.
- Under no circumstances should you ever take apart the product or alter it in any way. Doing so might result in the product becoming damaged during operation or the product becoming unable to operate properly.

## **HANDLING FUEL**

- The engine is designed to run on gasoline, which contains highly flammable gasoline. Never store cans of fuel or refill the tank of the unit in any place where there is a boiler, stove, wood fire, electrical sparks, welding sparks, or any other source of heat or fire which might ignite the fuel.
- Never smoke while operating the unit or refilling its fuel tank.
- When refilling the tank, always turn off the engine and allow it to cool down. Take a careful look around to make sure that there are no sparks or open flames anywhere nearby before refueling.
- Wipe spilled fuel completely using a dry rag if any fuel spillage occurs during refueling.
- After refueling, screw the fuel cap back tightly onto the fuel tank and then carry the unit to a spot 3 m or more away from where it was refueled before turning on the engine.

## **TRANSPORT AND STORAGE**

- When you finish cutting in one location and wish to continue work in another spot, turn off the engine, lift up the unit and carry it paying attention to the blade.
- When transporting or storing the machine always fit the cutting device guard or guide bar cover.
- When hand-carrying the product, cover over the cutting part if necessary, lift up the product and carry it paying attention to the blade.
- Never transport the product over rough roads over long distances by vehicle without removing all fuel from the fuel tank. If doing so, fuel might leak from the tank during transport.
- Protect the machine from damage when transporting it.
- When transporting or storing the machine, always fit the cutting device transport guard.

## **KICKBACK SAFETY PRECAUTIONS**

### **▲ DANGER**

Kickback may occur when the nose or tip of the guide bar touches an object, or when the wood closes in and pinches the saw chain in the cut. Tip contact in some cases may cause a lightning fast reverse reaction, kicking the guide bar up and back towards the operator. Pinching the saw chain along the top of the guide bar may push the guide bar rapidly back towards the operator. Either of these reactions may cause you to lose control of the saw, which could result in serious personal injury.

Do not rely exclusively on the safety devices built into your saw. As a chain saw user you should take several steps to keep cutting jobs free from accident or injury.

- With a basic understanding of kickback you can reduce or eliminate the element of surprise. Sudden surprise contributes to accidents.

- Keep a good grip on the machine with both hands, the right hand on the rear handle, and the left hand on the front handle, when the engine is running. Use a firm grip with thumbs and fingers encircling the machine handles. A firm grip will help you reduce kickback and maintain control of the machine.
- Make certain that the area in which you are cutting is free from obstructions. Do not let the nose of the guide bar contact a log, branch, or any other obstruction which could be hit while you are operating the machine.
- Cut at a high engine speed.
- Follow the manufacturer's sharpening and maintenance instructions for the saw chain.
- Only use replacement bars and chains specified by the manufacturer or the equivalent.

#### **⚠ DANGER**

**Make sure the chain and guide bar are correctly adjusted before operating the equipment . Never attempt chain adjustment with the engine running!**

- Always make sure the cutting attachment is properly installed and firmly tightened before operation.
- Never use a cracked or warped guide bar: replace it with a serviceable one and make sure it fits properly.
- If a saw chain should bind fast in a cut, shut off the engine immediately. Push the branch or tree to ease the bind and free the saw chain.
- Do not operate the machine with the muffler removed.
- When cutting a limb that is under tension, be alert for springback so that you will not be struck by the moving limb.
- Always stop the engine immediately and check for damage if you strike a foreign object or if the machine becomes tangled. Do not operate with broken or damaged equipment.

#### **⚠ WARNING**

**Do not make unauthorized modifications or substitutions to the guide bar or chain.**

**Never allow the engine to run at high speed without a load. Doing so could damage the engine.**

**Keep the machine as clean as possible. Keep it free of loose vegetation, mud, etc**

- If this model has a chuck, check regularly if the cutting attachment stops turning when the engine idles.
- Always inspect the tool before use and after dropping or other impacts to identify any significant defects. If some defects are observed, do not use the tool and bring it to a qualified service for inspection and repair.
- Be careful to exhaust gas when operation. Avoid inhaling them and wearing a mask of protection during operation.
- Prolonged use of this product exposes the operator to vibration and can produce so-called "white finger" disease. To reduce the risk, wear gloves and keep your hands warm.
- If any of the symptoms of "white finger syndrome" occur, seek immediate medical attention. Symptoms of the "white finger" include numbness, loss of sensitivity, tingling, tingling, and pain, loss of strength, color changes or skin condition. These symptoms usually appear on the fingers, hands or wrists. Risk increases at low temperatures.
- To reduce the risk, limit the time of operation of the tool and do not use it for a long time. Take some rest during two operations.

#### **Residual risks**

**Even when the tool is used as prescribed it is not possible to eliminate all residual risk factors. The following hazards may arise in connection with the tool's construction and design:**

1. Damage to lungs if an effective dust mask is not worn.
2. Damage to hearing if effective hearing protection is not worn.
3. Health defects resulting from vibration emission if the power tool is being used over longer period of time or not adequately managed and properly maintained.

### Intended use

This appliance is designed for the following applications:

#### **- Brush cutter (when fitted with metal circular blade)**

The brush cutter is intended to cut weed and climbing plants. Do not use it for other purposes, never use it for cutting wood. Never cut objects with a diameter exceeding 13mm.

#### **- Grass trimmer (when fitted with nylon line cutting head)**

The grass trimmer is intended for trimming grass. Do not use it for other purposes.

#### **- Pruner (when fitted with saw chain)**

The pruner (pole saw) is intended to be used for trimming fruit trees, cutting back overhanging branches, thinning out treetops and cutting off buckled branches.

#### **- Hedge trimmer (when fitted with reciprocating blade)**

The trimmer is intended to be used for trimming hedges and bushes with diameter not more than 24mm.

Do not use this appliance for other purpose than those described in this manual.

**Note:** National regulation can restrict the use of the machine.

### Symbols



- Warning



- Read the user manual before using the machine.



- Beware of flying objects



- Keep bystanders at least 15 m away



- Beware of sharp blades



- Beware of foot injury



- Beware of falling objects



- Beware of blade thrust



- Wear eye protection, ear mufflers and helmet



- Wear sturdy boots to protect yourself from slipping



- Wear glove to protect your hands



- Always beware of the danger from overhead electric-power line, keep a safe distance at least 10m from the power line



Be aware of kickback



No fire, no unprotected source of light, no smoking



Wear full protective equipment: helmet, glasses and ear protection



For safe operation and maintenance, symbols are carved in relief on the machine. According to these indications, please be careful not to make a mistake.

The port to refuel the "GASOLINE"

**Position: FUEL TANK CAP**



Guarantee sound power level



Hot surface



Do not use under rain



Do not use metal saw blade

## 2. PRODUCT

---

### a. Description

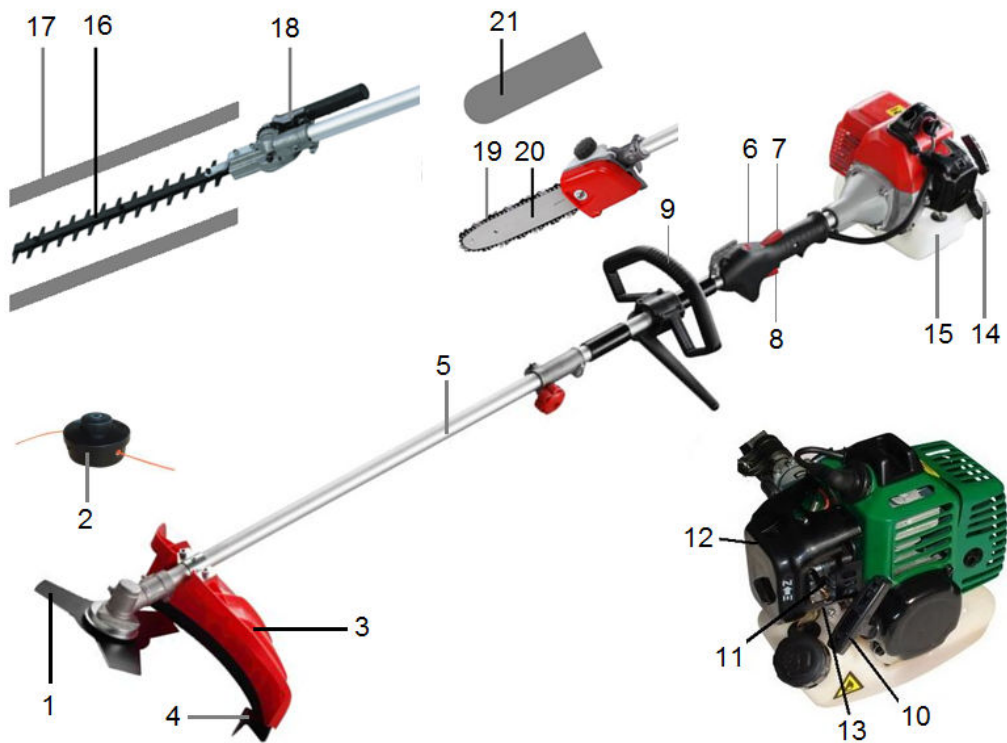

1 BLADE (2/3/4 teeth)

4 CUT-OFF KNIFE

7 SAFETY LEVER

10 STARTER HANDLE

13 PURGE BULB

16 Cutting unit (hedge trimmer)

19 Saw chain

2 NYLON CUTTER HEAD

5 DRIVE SHAFT ASSEMBLY

8 THROTTLE TRIGGER

11 CHOKE

14 FUEL TANK LID

20 Guide bar

3 Carter of protection

6 IGNITION SWITCH

9 HANDLE

12 AIR CLEANER COVER

15 FUEL TANK

18 Adjusting handle lock lever

#### **The tool is delivered with:**

- 1 extension tube
- 1 Tool kit (wrenches, keys, spanner)
- 1 Bottle for fuel filling



## **b. Technical specifications**

### **MODEL**

### **RAC4KIT-B**

|  |  |
|--|--|
| Model of Engine  | SPK36F   |
| Engine type  | Air-cooled; 2 cycle; vertical<br>Piston valve; gasoline engine |
| Engine displacement  | 33 cm <sup>3</sup>   |
| Max. engine power  | 1.0kW  |
| Engine speed at idling                                       | 3000+/-200 min <sup>-1</sup>                                   |
| Max. engine speed  | 10000 min <sup>-1</sup>  |
| Fuel used  | Gasoline mixed with lubricating oil<br>(ratio of 40:1)         |
| Fuel tank capacity   | 960 cm <sup>3</sup>  |
| Specific fuel consumption at max. engine performance (g/kwh) | 503 g/kWh  |
| Weight of tool (no fuel, no cutting attachment)              | 6,55 kg  |
| Volume of oil tank (saw chain lubricating)                   | 150 cm <sup>3</sup>  |
| Guarantee sound power level                                  | 113 dB(A)  |
| Maximum frequency of the spindle                             | 8000/min   |

### **Grass trimmer**

|  |                         |
|--|-------------------------|
| Line Max. Cutting                        | 44 cm                   |
| Type of cutting line                     | PA6                     |
| Maximum rated rotational frequency       | 10000 min <sup>-1</sup> |
| Noise(in accordance with ISO 22868):     |                         |
| - Sound pressure level                   | 96.33 dB(A)             |
| - Sound power level                      | 109.87 dB(A)            |
| - Uncertainty K                          | 3 dB(A)                 |
| Vibration(in accordance with ISO 22867): |                         |
| - Front handle:                          | 5.386 m/s <sup>2</sup>  |
| - Rear handle                            | 6.543 m/s <sup>2</sup>  |
| - Uncertainty K                          | 1.5 m/s <sup>2</sup>    |

### **Brush cutter**

|  |                         |
|--|-------------------------|
| Blade type                               | 3 tooth metal blade     |
| Cutting diameter                         | 230mm x 25,4mm x 1,4mm  |
| Maximum rated rotational frequency       | 12000 min <sup>-1</sup> |
| Noise(in accordance with ISO 22868):     |                         |
| - Sound pressure level                   | 95.41 dB(A)             |
| - Sound power level                      | 108.87 dB(A)            |
| - Uncertainty K                          | 3 dB(A)                 |
| Vibration(in accordance with ISO 22867): |                         |

|                 |                        |
|-----------------|------------------------|
| - Front handle: | 5.162 m/s <sup>2</sup> |
| - Rear handle   | 7.138 m/s <sup>2</sup> |
| - Uncertainty K | 1.5 m/s <sup>2</sup>   |

**Hedge trimmer:**

|   |   |
|---|---|
| Cutting length of trimmer blade:            | 390mm                                     |
| Cutting capacity                            | Ø 24mm                                    |
| Noise(in accordance with EN ISO 10517):     |   |
| - Sound pressure level                      | Racing: 94.78 dB(A); idling: 77,65 dB(A)  |
| - Sound power level                         | Racing: 110.02 dB(A); idling: 85,24 dB(A) |
| - Uncertainties K                           | 3 dB(A)                                   |
| Vibration(in accordance with EN ISO 10517): |   |
| - Declared value                            | 11.713 m/s <sup>2</sup>                   |
| - Uncertainty K                             | 1.5 m/s <sup>2</sup>                      |

**Pruner:**

|                        |                          |
|------------------------|--------------------------|
| Bar length             | 10 inches (254mm)        |
| Max. Cutting Length    | 245 mm                   |
| Chain speed at no load | 10 m/s                   |
| Type of guide bar      | AL 10-39-507P            |
| Type of saw chain      | Alp-50-39S               |
| Chain pitch            | 9.525mm (3/8")           |
| Chain gauge            | 1.27 mm (0.05")          |
| Sprocket               | 7 theets×9.525 mm (3/8") |

|  |                        |
|--|------------------------|
| Noise(in accordance with ISO 22868):     |                        |
| - Sound pressure level                   | Racing: 95.62 dB(A)    |
| - Sound power level                      | 110.05 dB(A)           |
| - Uncertainty K                          | 3 dB(A)                |
| Vibration(in accordance with ISO 22867): |                        |
| - Front handle:                          | 6.293 m/s <sup>2</sup> |
| - Rear handle                            | 7.290 m/s <sup>2</sup> |
| - Uncertainty K                          | 1.5 m/s <sup>2</sup>   |

### 3. ASSEMBLY

---

#### a. Main unit

Use gloves when mounting the tool. Be careful of sharp edges and cutting elements.

##### Extension bar

- Pull the ring out
- Insert the attachment to the main shaft. Fix the pin into the hole;
- Tighten the knob bolt securely.

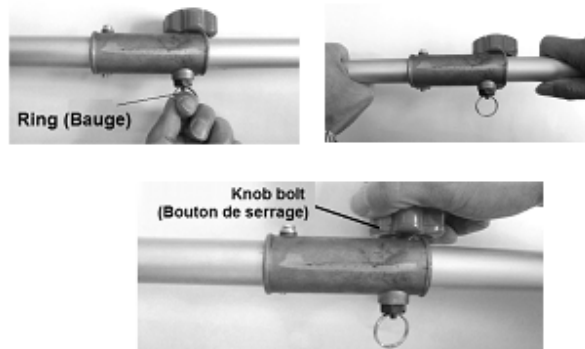

##### Handle

- If necessary, unscrew with a spanner the handle and the barrier.
- Install the handle and barrier to the aluminum tube.
- Fasten the 4 internal hexagonal screws with spanner.

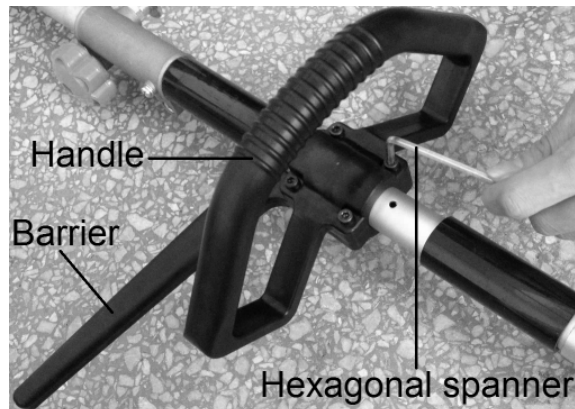

**b. Pole pruner**

Installing chain and guide bar

- Place the sawing chain onto the sawing rail.

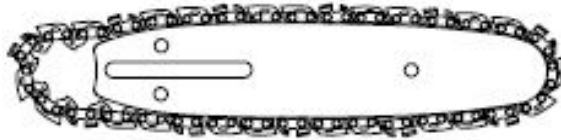

- Open the cover sprocket by unscrew the screw with the provided wrench.
- Position the guide bar so that the chain tensioning stud projects into the guide bar, Ensure that the saw chain runs in the correct direction!

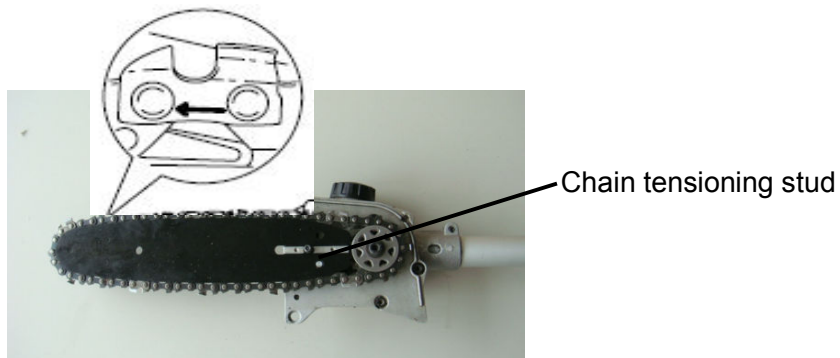

- Reinstall the cover and then tighten the fixing bolt lightly.

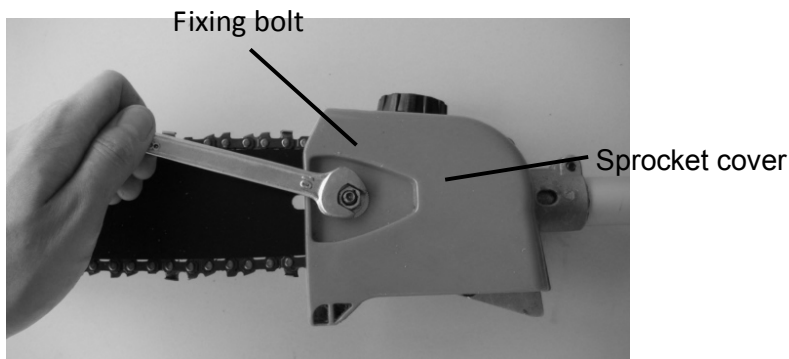

- Tighten the tensioning screw.

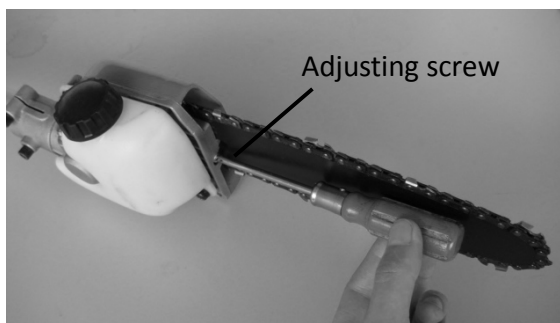

- Tighten the fixing nut.
- Install the pole pruner part on the main unit.

## NOTE!

The chain should not sag, but it should be possible to pull it a few millimeters away from the saw rail.

### Set the chain tension

#### **⚠ WARNING**

- The saw chain has very sharp edges. Use protective gloves for safety.
- Always pay attention to the chain tension. A slackened chain will increase the risk of backlash. If slackened, the chain could spring out of the guide, could cause injury to the operator and get damaged. A slackened chain wears out very quickly and the sprocket wheel and the guide bar wears out

- Unscrew the fixing nut.

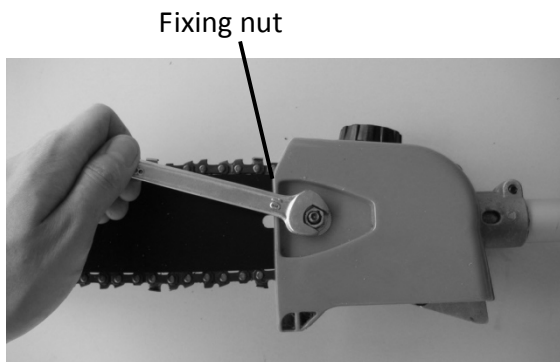

- Turn the adjusting screw until the chain fits but may be moved with ease.

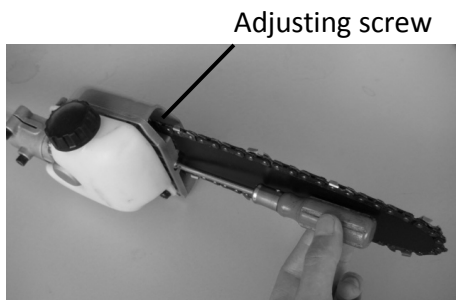

### c. Brushcutter and grass trimmer

#### Carter of protection

- Install the carton the bar and align the holes. Screw it with the two provided screws. Make sure that the carter is installed in correct way.



#### Cutting device for grass trimmer

- Put a spanner in the hole of the cap and the hole shaft to block it. Remove the screw with a wrench (provided).



#### Cutting device (brushcutter)

- Put a spanner in the hole of the cap and the hole shaft to block it. Remove the screw with a wrench (provided).
- Remove then the plate



- Install in place one blade for brushcutter. Install then the plate on the blade.
- Put the screw and screw it to fix the blade and nut in place.

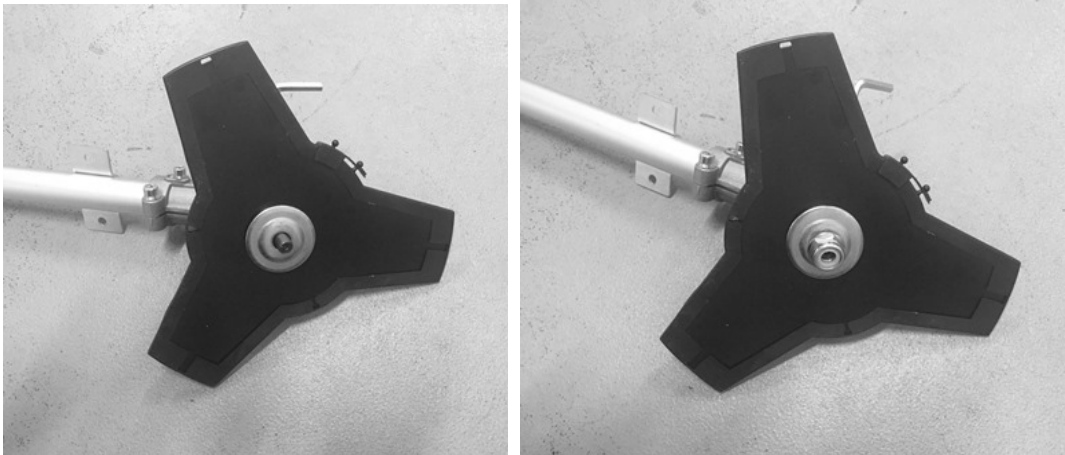

- Install the bar of the brush cutter on the main unit. Make sure that it is securely fixed.

**d. Hedge trimmer**

- Unscrew the locking screw. Install the hedge trimmer in the extension tube. Screw then the screw to fix the hedge trimmer.



**c. Installation of the harness**

Caution: Always use the harness when using the tool.

Attach the harness as soon as you have started the engine and the engine is idling. Stop the engine before removing the harness

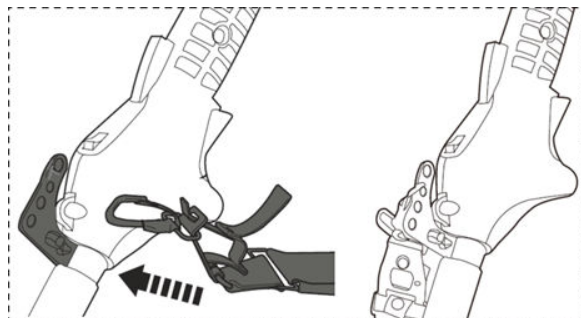

## 4. FUEL FILLING

---

### a) Fuel

- **Warning: Gasoline is highly flammable. Keep the fuel in specially designed cans.**
- **Only fill the tank outside and do not smoke during the operation. Avoid sparks or open flames near the fuel.**
- **Fill the tank before starting the engine. Never remove the fuel tank cap, add fuel while the engine is still running, or while the engine is still warm.**
- **Avoid overfilling the tank: When excess fuel has escaped, do not attempt to start the engine, but move the machine away and avoid any sources of ignition in the vicinity until the fuel vapors have dissipated.**
- **Fully tighten all fuel filler caps and cans.**
- **Fill the tank on the floor.**
- **The engine must be started at a distance of at least 3 meters from where the fuel tank has been filled.**
- **Switch off the engine before adding fuel. Shake the mixture thoroughly before filling the tank.**
- **Store gasoline in tanks specially designed for this purpose.**
- **Fill the fuel tank of your appliance outdoors and avoid smoking during work.**
- **Fill the tank before starting the engine. Never open the fuel tank cap or fill fuel tank while the engine is running or the engine is still hot.**
- **Avoid spilling gasoline: When gasoline is spilled, do not start the machine and move it away from where the gasoline has spilled to avoid possible sources of fire.**
- **Screw all caps and tank cover carefully.**

This type of tool is designed to be used with unleaded gasoline. Using unleaded gasoline prevents unnecessary pollution in the interests of your health and the protection of the environment. Using gasoline or oil of lesser quality can damage seal rings, ducts or fuel tank.

Exhaust emissions are regulated by the basic technical characteristics of the engine and its components (carburation, adjustment of spark plugs, control of exhaust opening and closing times) in the absence of accessories or a catalyst during combustion.

### Fuel mixture

MIXTURE RATIO IS 40:1 (GASOLINE-40PART/OIL-1 PART)

Fuel mixture at the rate other than 40:1 may cause damage to the engine, Ensure mixture ratio is correct.

Make the mix in the provided container. Mix thoroughly and carefully during one minute.

### Filling the tank

- Unscrew the tank cap.
- Fill the tank to 80% of its capacity.
- Screw the fuel cap back on. Clean the fuel tank cap and the area around after filling the fuel tank. Eliminate overfill of fuel mixture by rubbing.

### Storing and disposal of fuel

Store fuel only in a clean, safe and approved container. Check and follow local ordinances on type and location of storage container and for the disposal of the fuel.



## 5. OPERATION

---

### a. Before operation

#### **⚠ WARNING**

For your safety, and to maximize the service life of your equipment, it is very important to take a few moments before you operate the engine to check its condition. Be sure to take care of any problem you find, or have your servicing dealer correct it.

Before beginning your pre-operation checks, be sure the engine stop switch is in the OFF position.

Always check the following items before you start the engine:

- Cutting head correct mount.
- Switches easy run.
- Mounting and cleanliness of the handles
- The cutting head must move freely.
- Check and adjust the harness to suit for your body size.
- Check the damage of parts including the cutting device.
- To reduce fire hazards, keep the engine and silencer free of debris, leaves and excessive lubricant.

#### **⚠ DANGER**

If in doubt when putting the machine in operation, take advice from a professional of an authorized servicing centre. Non-professional advice may be dangerous to life!

### b. Starting

#### Cold starting

- Move the stop switch to "START" position.
- Give a gentle push on the primer pump repeatedly (7-10times) until fuel comes into the primer pump.
- Pull lever up to close choke.
- Pull starter handle until engine flash.
- Push choke lever inwards (excessive cranking with choke lever will cause flooding engine making it difficult to start).
- Pull starter handle until engine starts.
- Allow engine to warm up for a few minutes before using.

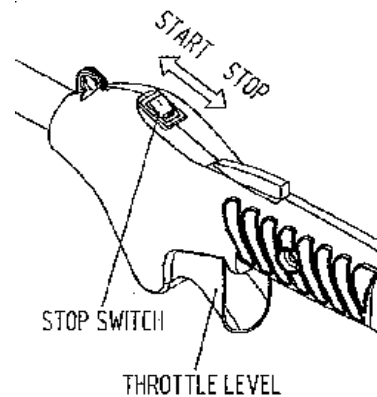

#### Hot starting

- If fuel tank was not run dry, pull starter. One to three times and should start. If fuel tank was run dry, after refilling repeat the steps as stated in the chapter "cold starting".

### c. Stopping the engine

- Move switch to STOP position

### d. Pole pruner operation

#### **⚠ DANGER**

- Always wear protective equipment such as gloves, eyes and ear protection.
- Falling branches may fall onto the face or into the eyes, resulting in injuries, scratches, and

cuts, and for this reason you should always be sure to wear a helmet and face protector when using your pole saw.

- Beware of the rebound branches after they fall down and hit the ground.
- The pruner shall be held with the right hand on the rear handle and the left hand on the front handle.

#### Checking oil supply

After starting the engine, run the chain at medium speed and see if chain oil has scattered off, as shown in the figure.



#### **NOTE!**

The oil reservoir has a capacity sufficient to provide about 40 minutes of cutting time (when set to deliver the minimum flow rate, or about as long as you'll get from a tank of fuel). Be sure to refill the oil tank every time when refueling the saw.

#### Adjusting oil flow rate

##### **▲ CAUTION**

**Never fill the oil reservoir or adjust the oiler with the engine running.**

**An increase in bar oil flow rate will speed oil consumption, requiring more frequent checks on the oil reservoir. To ensure sufficient lubrication, it may be necessary to check the oil level more frequently than at fuel tank refills.**

**The guide bar and chain are lubricated automatically by a pump that operates whenever the chain rotates. The pump is set at the factory to deliver a minimum flow rate, but it can be adjusted in the field. A temporary increase in oil flow is often desirable when cutting things like hardwood or wood with a lot of pitches.**

Adjust the pump as follows:

- Stop the engine and make sure the stop switch is in the "O" position.
- Place the unit on its side with the oil reservoir up.
- With a screwdriver, push in on the oil flow rate adjusting screw and turn in the desired direction

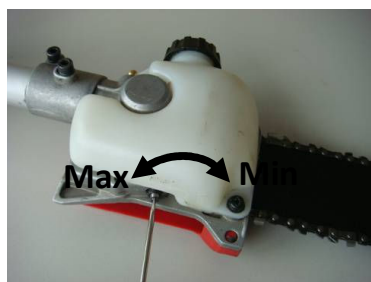

##### **▲ CAUTION**

**The oil flow adjusting screw must be pressed in slightly in order to turn. Failure to do so could damage the pump and screw.**

#### Working with the pole chain saw

- Do not work with an angle higher than 60°. The pole saw will work under higher degrees, but there is the

danger of being injured by branches falling without warning. Keep an eye at the ground while working to avoid tripping over fallen branches.

- Never use the pruner without oil, use bio-degradable chainsaw oil. Please keep in mind that this pruner, like all chainsaws, flings oil from the chain during operation. Protect yourself from falling oil drops with suitable protective glasses and clothing.
- To operate the pruner, press down the throttle lockout and then pull the throttle trigger.
- The pruner is equipped with a low-kickback chain and it was also done everything from an engineering point of view to keep kickback low. Nevertheless, some kickback can not be avoided when cutting with the upper tip of the blade. Be prepared for some kickback when using this area of the blade or hitting another branch with this area. Always hold the unit firmly in both hands.
- Thin branches can be cut off with one single cut. To prevent the branch from splintering the branch should be cut off in several pieces.
- When cutting off larger branches, you should first cut into the branch from below. First cut into the branch from below outside the place where you intend to cut off the branch. The cut should go from one third to halfway through the branch. This prevents the branch from buckling when you cut into the branch from the top outside the first cut. Last, cut off the stump with one clean cut. You might want to seal the cut with a suitable compound.

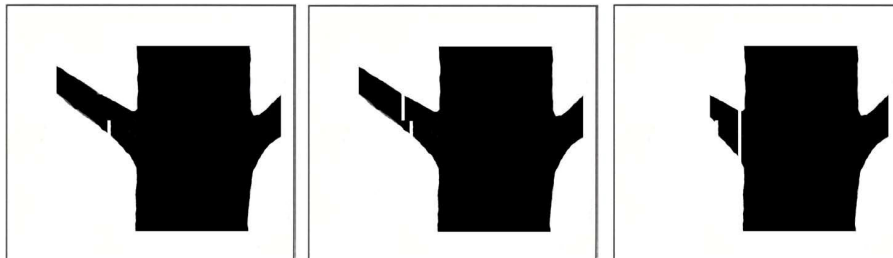

First Cut

Second Cut

Third Cut

#### e. Hedge trimmer operation

##### **⚠ DANGER**

**This product is equipped with extremely sharp blades, and when used improperly these blades can be extremely dangerous and improper handling can cause accidents, which may in turn lead to serious injury or death. For this reason, you should always be careful to follow the following instructions when using your trimmer.**

- Never hold the trimmer in a way in which the blades are pointed towards someone else.
- Never allow the blades to come into proximity with your body while the engine of the trimmer is in operation.
- Always be sure to turn off the engine before changing the angle of the blades, removing branches which have become stuck in the blades, or at any other time when coming into close proximity with the blades.
- Always wear work gloves made of leather or some other sturdy material when using the trimmer.
- Always place the blade cover provided with the trimmer over the blades when not in use.
- Falling branches may fall onto the face or into the eyes, resulting in injuries, scratches, and cuts, and for this reason you should always be sure to wear a helmet and face protector when using your trimmer.

##### **⚠ CAUTION**

**The thickness of branches, which may be cut using this trimmer, is limited to up to approximately 24 mm. Never try to cut branches thicker than this, as doing so may result in damage to the trimmer.**

### Adjusting the angle of the cutting blades

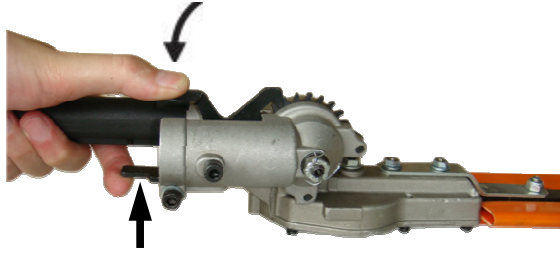

- Stop the engine.
- Lift the lock lever and press down the adjusting lever.
- Adjust the angle of the blades to the desired angle and lose your hand.

### **f. Brushcutter operation**

Grab the device with the right hand at the rear handle and with the left hand at the front handle. Try to hold the device at a comfortable level of your hip and always use both hands. Always make sure you stand firmly, so that a possible setback does not make you loose balance.

#### **▲ WARNING**

- Respect municipal and communal regulations when operating the machine.
- Do not use the machine during general rest periods.
- Hard objects – stones, metal work etc. – have to be removed. They could be slung away, which could result in injury and damage to property.
- Work in height shrubs and bushes. The working height must be at least 15 cm high to not put an animal, e.g. hedgehog, in danger.
- Check and clean the area from hidden objects like stones, glass, fences, wood etc.
- Never use the blade near curbs, fences, buildings or other immobile objects.
- Do not use the blade after hitting a hard object and without inspection. Do not use it after you discovered damages.
- The device can be used as a scythe by cutting from right to left in a large movement.

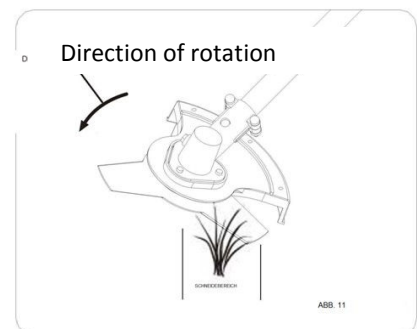

### Blade thrust

Take great care using the blade with the device. Thrust is a reaction that occurs when the blade hits objects that it can not cut. This can make the blade stop and “push away” the tool from the object that was unable to be cut. This reaction can be intense enough to lose control about the object, this process can occur without a warning, as soon as the blade hits an obstacle and stands still. It will occur in areas, where you cannot see exactly what you are cutting. This is why you always should cut from right to left to minimize the reactions.

### **g. Grass trimmer operation**

- Hold the machine safely with both the hands.
- Trim the grass and weed only, low shrubbery may be cut with a thick blade.
- Work in a manner and do not threaten anybody while mowing. Work quietly and considerately!
- Work only in conditions of sufficient visibility and sufficient light!
- Never mow/cut above the height of your shoulders!

- Never replace the plastic cord with steel wire – risk of injury and destruction!
  - Never work standing on a ladder!
  - Work on strong and stable bases!
  - Use the unit after you have read the operating instructions carefully.
  - Observe all the safety instruction in the manual.
  - Be responsible to the others.
  - To turn the machine off, put the switch on the “O” position.
  - Respect municipal and communal regulations when operating the machine.
- Do not use the machine during general rest periods.
- Any hard objects – stones, metal parts etc. – have to be removed. They could be thrown away and cause personal or material damage.
- Working in high shrubs or bushes, the working height must be 15 cm as a minimum not to expose animals, such as hedgehogs at any risk.

#### Grass Trimming

While working on grass areas, hold the machine at an angle of approx. 30° and make semicircle turns to the left and right.

The best results are achieved with grass 15 cm high. If it is higher, it is recommended to repeat mowing several times.

**CAUTION! When the machine is running never put the cutting head on the ground.**

#### **If the trimming output decreases**

- Hold the running machine over the grass and knock the ground several times with the cutting head the nylon line will get prolonged in thus way.
- The cutter enclosed in the protection shield will cut the nylon line to the required length.

If the machine is vibrating, clean it or, where necessary, and remove the grass stuck on the cutting head and protection shield.

## **6. MAINTENANCE**

---

Good maintenance is essential for safe, economical and trouble-free operation. It will also help reduce pollution.

### **⚠ DANGER**

- **Improper maintenance, or failure to correct a problem before operation, can cause a malfunction in which you can be seriously hurt or killed.**
- **Always follow the inspection and maintenance recommendations and schedules in this owner’s manual.**

To help you properly care for your equipment, the following pages include a maintenance schedule, routine inspection procedures, and simple maintenance procedures using basic hand tools. Other service tasks that are more difficult, or require special tools, are best handled by professionals and are normally performed by our dealer or other qualified mechanic.

### **⚠ WARNING**

- **Make sure that the engine has stopped and the sparkplug wire is disconnected, and is cool before**

performing any service to the machine. Contact with moving cutting head or hot muffler may result in a personal injury.

- Read the instructions before you begin, and make sure you have the tools and skills required.
- To reduce the possibility of fire or explosion, be careful when working around gasoline. Use only a nonflammable solvent, not gasoline, to clean parts. Keep cigarettes, sparks and flames away from all fuel related parts.

### a. MAINTENANCE SCHEDULE

| Maintenance        |                             | Each time you use               | 1 month/ 5 hours | 3month/ 25 hours     | 6 month/ 50 hours    | 12month/ 100hours     | 24month/ 250hours       |
|--------------------|-----------------------------|---------------------------------|------------------|----------------------|----------------------|-----------------------|-------------------------|
| System/components  |                             |                                 |                  |                      |                      |                       |                         |
| air cleaner        | check                       | ■                               |                  |                      |                      |                       |                         |
|                    | clean                       |                                 |                  | ■a                   |                      |                       |                         |
| spark plug         | Check and adjustment        |                                 |                  |                      |                      | ■                     |                         |
|                    | replacement                 |                                 |                  |                      |                      |                       | ■                       |
| clutch             | check                       |                                 |                  |                      | ■b                   |                       |                         |
| Valve clearance    | replacement                 |                                 |                  |                      |                      | ■b                    | ■b                      |
| Combustion chamber | clean                       | After every 250 hours operation |                  |                      |                      |                       |                         |
| Fuel filter        | check                       |                                 |                  |                      |                      | ■                     |                         |
| fuel pipe          | check                       | Every 2 years                   |                  |                      |                      |                       |                         |
| others             | System/components           | Procedure                       | Before use       | Every 25 hours after | Every 50 hours after | Every 100 hours after | Note                    |
|                    | throttle lever, stop switch | check operation                 | ✓                |                      |                      |                       |                         |
|                    | cutting parts               | replace if something's wrong    | ✓                |                      |                      |                       | Pole hedge trimmer only |
|                    | transmission                | grease                          |                  | ✓(b)                 |                      |                       |                         |
|                    | screws/nuts/bolts           | tighten/replace                 | ✓                |                      |                      | ✓                     | Not adjusting screws    |
|                    | guide bar                   | clean                           | ✓                |                      |                      |                       | Pole chain saw only     |
|                    | sprocket                    | inspect/replace                 |                  |                      | ✓                    |                       | Pole chain saw only     |
|                    | saw chain                   | inspect/sharp                   | ✓                |                      |                      |                       | Pole chain saw only     |

(a)Service more frequently when used in dusty areas.

(b)These items should be serviced by your servicing dealer, unless you have the proper tools and are mechanically proficient.

### b. ENGINE

#### AIR FILTER

The air cleaner clogged, will reduce the engine performance. Check and clean the filter element in warm, soapy water as required. Dry completely before installing. If the element is broken or shrunk, replace with a new one.

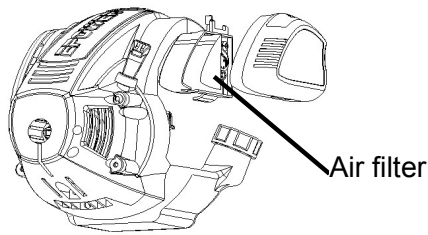

## SPARK PLUG

Starting failure and misfiring are often caused by a fouled spark plug. Clean the spark plug and check that the plug gap is in the correct range.

To replace the demolished spark plug with a new one with same specifications.

Remove carbon

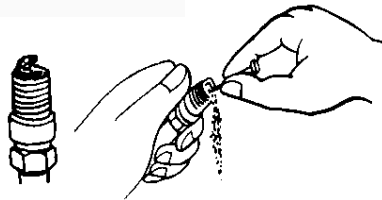

Demolished spark plug

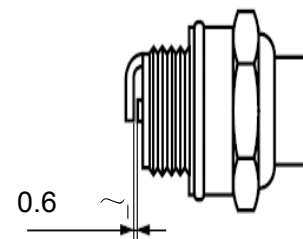
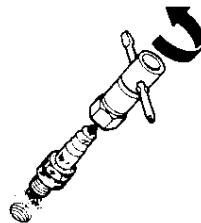

### ⚠ CAUTION

- Note that using any spark plug other than those designated may result in the engine failing to operate properly or in the engine becoming overheated and damaged.
- To install the spark plug, first turn the plug until it is finger tight, then tighten it a quarter turn more with a socket wrench.

## MUFFLER

### ⚠ WARNING

- Inspect periodically, the muffler for loose fasteners, any damage or corrosion. If any sign of exhaust leakage is found, stop using the machine and have it repaired immediately.
- Note that failing to do so may result in the engine catching on fire.

Remove the muffler, insert a screwdriver into the vent, and wipe away any carbon buildup. Wipe away any carbon buildup on the muffler exhaust vent and cylinder exhaust port at the same time.



## HEDGE TRIMMER:

### BLADE:

- When refilling the tank or resting, it is often a good idea to use the time to oil the cutting blades.
- If a gap exists between the upper and lower blades, follow the procedure below to adjust them so that they fit more closely together.

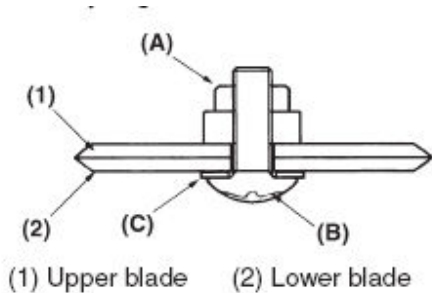

1. Loosen lock nut (A) as shown in the diagram.
2. Tighten screw (B) fully, and then turn one-third to one half of a rotation backward.
3. While holding onto the screw to keep it in position, tighten the lock nut.
4. Check to make sure that the flat washer (C) is loose enough so that it may be turned by pressing on it.

### NOTE!

Screwing in the screw too tightly may make it impossible for the blades to move. Conversely, not screwing in the screw tightly enough may make the blades of the trimmer feel dull and cause leaves and branches to become caught in the blades of the trimmer.

### QUICK TIP

If the blades become so worn down that it is no longer possible to eliminate the gap between them, you should contact the dealer from which you purchased your trimmer to have the blades resharpened or replaced.

## POLE CHAIN SAW

### OILING PORT

Dismount the guide bar and check the oiling port for clogging.

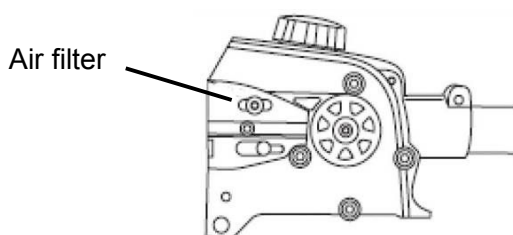

### GUIDE BAR

Remove sawdust in the bar groove and the oiling port.

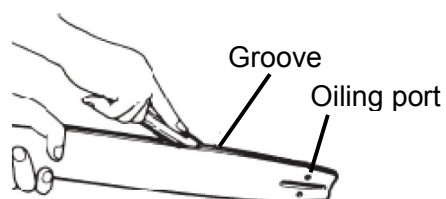



The bar rail should always be a square. Check for wear of the bar rail. Apply a ruler to the bar and the outside of a cutter. If a gap is observed between them, the rail is normal. Otherwise, the bar rail is worn. Such a bar needs to be corrected or replaced.

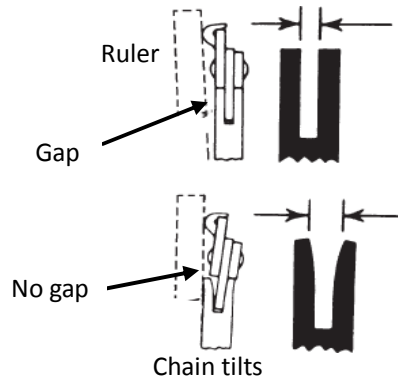

## SPROCKET

Check for extensive wear, and replace it when the teeth are worn over 0.3 mm.

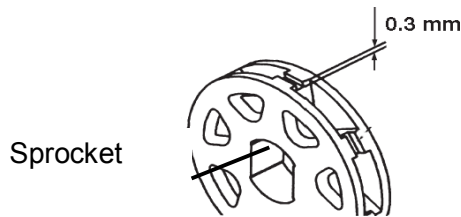

## SAW CHAIN

### Sharpening

#### ⚠ CAUTION

It is very important for smooth and safe operation to keep the cutters always sharp.

Your cutters need to be sharpened when:

- Sawdust becomes powder-like.
- You need extra force to saw in.
- The cut way does not go straight.
- Vibration increases.
- Fuel consumption increases.

#### ⚠ WARNING

Be sure to wear safety gloves.

Before sharpening:

- Make sure the saw chain is held securely.
- Make sure the engine is stopped.

Place your file on the cutter and push straightforward.  
Keep the file position as illustrated.

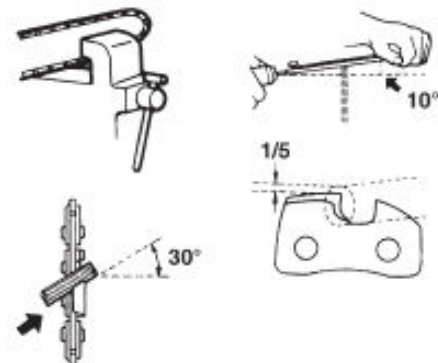

After every cutter has been set, check the depth gauge and file it to the proper level as illustrated.

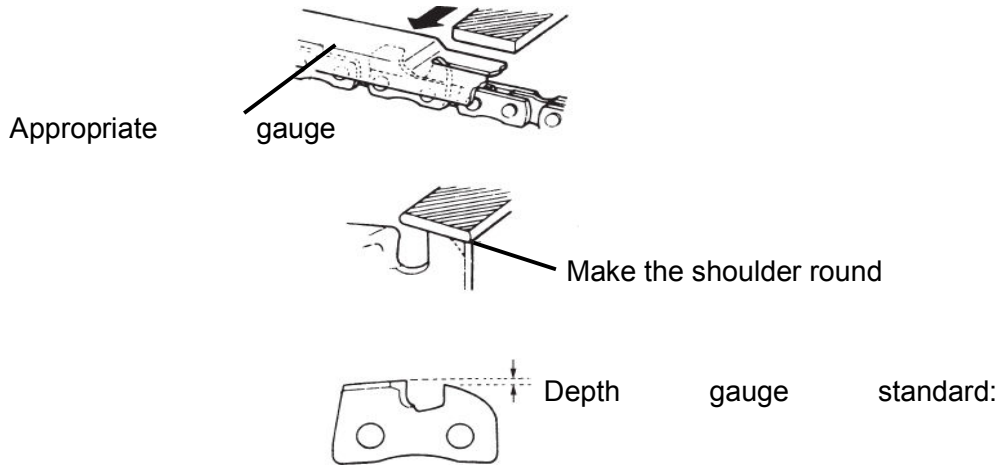

**Be sure to round off the front edge to reduce the chance of kickback**  
 Make sure every cutter has the same length and edge angles as illustrated.

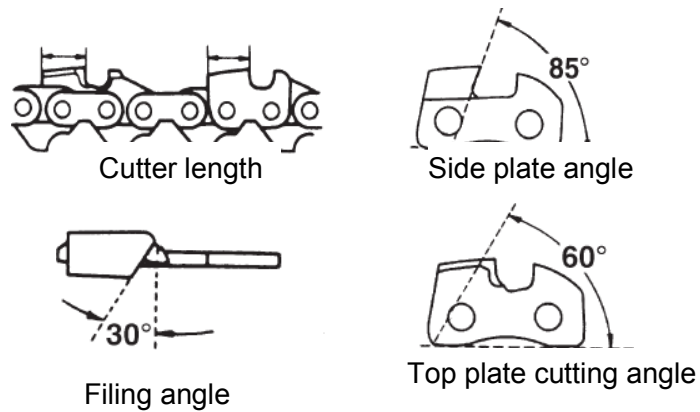

## TRANSMISSION

The reduction gears are lubricated by multipurpose, lithium-based grease in the transmission. Supply new grease every 25 hours of use or more often depending on the job condition. When adding lubricant, use a grease gun to insert lubricant into the three grease nipples located on the transmission.



**STORAGE**

Aged fuel is one of major causes of engine starting failure. Before storing the unit, empty the fuel tank and run the engine until it uses all the fuel left in the fuel line and the carburetor.

If the fuel tank is drained, this should be done outdoors.

Cleaning and maintenance the machine before storage.

Store the unit indoor without direct sunlight and taking necessary measures for rust prevention.

Store the unit in a locked place out reach of children.

Store the unit where the fuel vapour will not reach an open flame or spark. Always allow the machine to cool down before storing.

When storing the machine, always fit the cutting device transport guard.

**DISPOSAL**

When disposing your machine, fuel or oil for the machine, be sure to follow your local regulations.

**DECLARATION OF CONFORMITY EU**



**DECLARATION OF CONFORMITY EU**



**BUILDER SAS**

ZI, 32 RUE ARISTIDE BERGES 31270 CUGNAUX, FRANCE  
Tel : +33 (0)534.502.50 Fax : +33 (0)534.502.503

declares that the machines:  
**Multi-function Garden Tool**  
**Model: RAC4KIT-B**

Serial No.: from xxxxxxxx to xxxxxxxx

the people name holding the technical file: M. Olivier Patriarca

have been designed in compliance with the following standards:

EN ISO 11680-1:2011

EN ISO 11806-1:2011

**EN ISO 10517:2019**

EN ISO 14982: 2009

And in accordance with the following directives:

Directive Machine 2006/42/EC

Directive EMC 2014/30/EU

Noise Directive 2000/14/EC & Annex V Directive 2005/88/EC

Emission directive **2016/1628/EU & 2018/989/EU**

Guaranteed Sound power level according to 2000/14/EC: 113 dB(A)

Grass trimmer:

Sound power level (LwA) 109.87 dB(A)

Uncertainty K=3 dB(A)

Brush cutter:

Sound power level (LwA) 108.87 dB(A)

Uncertainty K=3 dB(A)

Hedge trimmer:

Sound power level (LwA) 110.02 dB(A)

Uncertainty K=3 dB(A)

Pruner:

Sound power level (LwA) 110.05 dB(A)

Uncertainty K=3 dB(A)

Philippe MARIE / PDG

30/08/2021

# WARRANTY



## WARRANTY

The manufacturer guarantees the product against defects in material and workmanship for a period of 2 years from the date of the original purchase. The warranty only applies if the product is for household use. The warranty does not cover breakdowns due to normal wear and tear.

The manufacturer agrees to replace parts identified as defective by the designated distributor. The manufacturer does not accept responsibility for the replacement of the machine, in whole or in part, and/or ensuing damage.

### The warranty does not cover breakdowns due to:

- insufficient maintenance.
- abnormal assembly, adjustment or operations of the product.
- parts subject to normal wear and tear.

### The warranty does not extend to:

- shipping and packaging costs.
- using the tool for a purpose other than that for which it was designed.
- the use and maintenance of the machine done in a manner not described in the user manual.

Due to our policy of continuous product improvement, we reserve the right to alter or change specifications without notice. Consequently, the product may be different from the information contained therein, but a modification will be undertaken without notice if it is recognized as an improvement of the preceding characteristic.

### READ THE MANUAL CAREFULLY BEFORE USING THE MACHINE.

When ordering spare parts, please indicate the part number or code, you can find this in the spare parts list in this manual. Keep the purchase receipt; without it, the warranty is invalid. To help you with your product, we invite you to contact us by phone or via our website:

- **+33 (0)9.70.75.30.30**
- **<https://services.swap-europe.com/contact>**

You must create a "ticket" via the web platform.

- Register or create your account.
- Indicate the reference of the tool.
- Choose the subject of your request.
- Describe your problem.
- Attach these files: invoice or sales receipt, photo of the identification plate (serial number), photo of the part you need (for example: pins on the transformer plug which are broken).



# PRODUCT FAILURE

## WHAT TO DO IF MY MACHINE BREAKS DOWN?

### If you bought your product in a store:

- a) Empty the fuel tank if your product has one.
- b) Make sure that your machine is complete with all accessories supplied, and clean! If this is not the case, the repairer will refuse the machine.

Go to the store with the complete machine and with the receipt or invoice.

### If you bought your product on a website:

- a) Empty the fuel tank if your product has one.
- b) Make sure that your machine is complete with all accessories supplied, and clean! If this is not the case, the repairer will refuse the machine.
- c) Create a SWAP-Europe service ticket on the site: <https://services.swap-europe.com> When making the request on SWAP-Europe, you must attach the invoice and the photo of the nameplate (serial number).
- d) Contact the repair station to make sure it is available before dropping off the machine.

Go to the repair station with the complete machine packed, accompanied by the purchase invoice and the station support sheet downloadable after the service request is completed on the SWAP-Europe site

For machines with engine failure from manufacturers BRIGGS & STRATTON, HONDA and RATO, please refer to the following instructions.

Repairs will be done by approved engine manufacturers of these manufacturers, see their site:

- <http://www.briggsandstratton.com/eu/fr>
- <http://www.honda-engines-eu.com/fr/service-network-page;jsessionid=5EE8456CF39CD572AA2AEEDFD290CDAE>
- <https://www.rato-europe.com/it/service-network>

**Please keep your original packaging to allow for after-sales service returns or pack your machine with a similar cardboard box of the same dimensions.**

**For any question concerning our after-sales service you can make a request on our website <https://services.swap-europe.com>**

**Our hotline remains available at +33 (9) 70 75 30 30.**



# WARRANTY EXCLUSIONS

## THE WARRANTY DOES NOT COVER:

- Start-up and setting up of the product.
- Damage resulting from normal wear and tear of the product.
- Damage resulting from improper use of the product.
- Damage resulting from assembly or start-up not in accordance with the user manual.
- Breakdowns related to carburetion beyond 90 days and fouling of carburetors.
- Periodic and standard maintenance events.
- Actions of modification and dismantling that directly void the warranty.
- Products whose original authentication marking (brand, serial number) has been degraded, altered or withdrawn.
- Replacement of consumables.
- The use of non-original parts.
- Breakage of parts following impacts or projections.
- Accessories breakdowns.
- Defects and their consequences linked to any external cause.
- Loss of components and loss due to insufficient screwing.
- Cutting components and any damage related to the loosening of parts.
- Overload or overheating.
- Poor power supply quality: faulty voltage, voltage error, etc.
- Damages resulting from the deprivation of enjoyment of the product during the time necessary for repairs and more generally the costs related to the immobilization of the product.
- The costs of a second opinion established by a third party following an estimate by a SWAP-Europe repair station
- The use of a product which would show a defect or a breakage which was not the subject of an immediate report and/or repair with the services of SWAP-Europe.
- Deterioration linked to transport and storage\*.
- Launchers beyond 90 days.
- Oil, petrol, grease.
- Damages related to the use of non-compliant fuels or lubricants.

\* In accordance with transport legislation, damage related to transport must be declared to carriers within 48 hours maximum after observation by registered letter with acknowledgement of receipt.

This document is a supplement to your notice, a non-exhaustive list.

**Attention:** all orders must be checked in the presence of the delivery person. In case of refusal by the delivery person, it you must simply refuse the delivery and notify your refusal.

**Reminder:** the reserves do not exclude the notification by registered letter with acknowledgement within 72 hours.

**Information:** Thermal devices must be wintered each season (service available on the SWAP-Europe site). Batteries must be charged before being stored.